

THE PRODUCTION CAPACITY OF RENEWABLE ENERGY FROM AVAILABLE BIOMASS INCLUDING AVAILABLE TECHNOLOGIES

Summary

It is essential to have knowledge of the volume and technologies of anaerobic digestion of biomass and of the ability to estimate it on an energetic basis in order to determine in the production of farm animals and use in practice the production capacity of renewable energy from animal excrement. The aim of this study is to demonstrate (illustrated with an example of communes of Budzyń, Kaźmierz, and Kostrzyn Wielkopolski) a method of collecting data and to determine mathematically biomass energy available in the animal production. Furthermore, there are reviewed some specific technologies of the biomass conversion in the agricultural biogas production. It has been assumed that data on the collection and processing of biomass for the energetic purposes and research results on the production capacity of biomass energy available in the animal production of the analysed communes will ensure that some activities aimed at popularizing any available and innovative agro-energetic technical and technological solutions in rural areas of the Wielkopolska Province will be conducted.

Key words: rural areas, biomass, renewable energy, agro-energetic installations

POTENCJAŁ WYTWÓRCZY ENERGII ODNAWIALNEJ Z DOSTĘPNEJ BIOMASY Z UWZGLĘDNIENIEM ZNANYCH TECHNOLOGII

Streszczenie

Do wyznaczenia w produkcji zwierząt gospodarskich i wykorzystania w praktyce potencjału wytwórczego energii odnawialnej z odchodów zwierzęcych, niezbędna jest wiedza o zasobności i technologiach biogazowania biomasy oraz umiejętność jej energetycznego oszacowania. Za cel opracowania przyjęto zaprezentowanie (na przykładzie gmin Budzyń, Kaźmierz, Kostrzyn Wielkopolski) sposobu gromadzenia danych i matematycznego wyznaczenia energii z biomasy dostępnej w produkcji zwierzęcej. Ponadto w produkcji biogazu rolniczego przedstawiono przegląd wybranych technologii konwersji biomasy. Założono, że informacje odnośnie pozyskiwania i przetwarzania biomasy na cele energetyczne, oraz wyniki badań o potencjale wytwórczym energii z biomasy dostępnej w produkcji zwierzęcej analizowanych gmin, zapewnią na obszarach wiejskich województwa wielkopolskiego działania do rozpowszechniania znanych, oraz nowatorskich technicznych i technologicznych, rozwiązań agroenergetycznych.

Słowa kluczowe: obszary wiejskie, biomasa, energia odnawialna, instalacje agroenergetyczne

1. Introduction

The gathering of organic biomass waste is a consequence of the development of civilization. This biomass may be processed into useful products, most notably energy and organic fertilizers for agriculture and gardening [20]. This requires to seek quality new technologies aimed at satisfying people's growing demand for energy and to carry out research and implementation activities directed towards the production of energy and industrial assets from any waste used [11]. The development of renewable energy is crucial for the achievement of fundamental objectives of the Poland's energy policy [15]. The increased use of energy sources leads to the greater independence from its imported sources and creates conditions for the development of the dispersed energy concept based on local raw materials [24]. As for the structure of the technical potential of raw materials used to produce biogas 80% of them are animal excrement [17]. Its share in the agricultural biogas production is undoubtedly essential to decrease the energy consumption that equalled to 3258.3 PJ in Poland in 2010 [7]. This is proved by research carried out by Grzybek [6]. That research proves that the production capacity of agricultural biogas made from manure and slurry of cattle, pigs and poultry equals to 194.9 PJ in Poland. According to Pawlak [17] the afore-mentioned types of farm animals

equal to over 90% of the livestock population. Therefore, the aim of this study is to present the biomass output (animal excrement) from the bedding, shallow bedding, and non-bedding systems used to keep livestock in the animal production in three rural communes of the Wielkopolska Province (Budzyń, Kaźmierz, and Kostrzyn Wielkopolski). Moreover, on the basis of the knowledge about the number of livestock units expressed by a large conversion unit, a determination method and the production capacity of agricultural biogas were discussed. It is estimated that the knowledge about the biomass availability in the animal production for energetic purposes will ensure that the analysed communes and rural areas of the Wielkopolska Province will have access to measures necessary to use well-known and new technical and technological solutions in renewable energy source systems.

2. The review of biomass conversion technologies

The equipment and installations for the production of agricultural biogas use biomass coming from special energy plant farms, by-products and waste of plant and animal origin [12]. There are many biogas production technologies known worldwide differing by a way of loading the fermentation chamber with biomass (continuous or periodic loading), place and insulation of the chamber (placed under the

ground level or placed on surface), type of insulation materials and consistency and content of the material designed for fermentation [14]. The largest number of simple agricultural biogas plants is located in China [11, 1]. Whereas, the most technologically advanced biogas plants are located in Japan, Korea, Germany, Sweden, Denmark, and Austria. However, the undisputed leader in this field is Germany where in the years 1992-2013 the number of biogas plants skyrocketed from 139 to 7874 [25]. In consideration of many well-known technologies used to convert biomass into energetic purposes, in this chapter the review of biomass conversion technologies is narrowed to selected technologies used to produce biogas from biomass of animal origin.

For small and medium farms biogas is produced by means of the technology developed by Reinhold Darmstadt [2, 5, 13, 14, 18]. The installation (Fig. 1.) comprises the concrete fermentation chamber, thermal insulation and two biogas tanks. The fermentation chamber (7 m long, 2 m wide and deep) is placed under the ground level. Fresh manure diluted with slurry is stored for a few weeks in the fermentation chamber wherein a biomass fermentation process takes place. Biogas produced during this process is preliminary stored in the biogas collection chamber and then in the relevant biogas tank equipped with a floating bell. This method is estimated to ensure an average daily biogas production of about 10 m³, and 1 m³ of the fermentation chamber produces from 0.3 to 0.5 m³ of biogas daily.

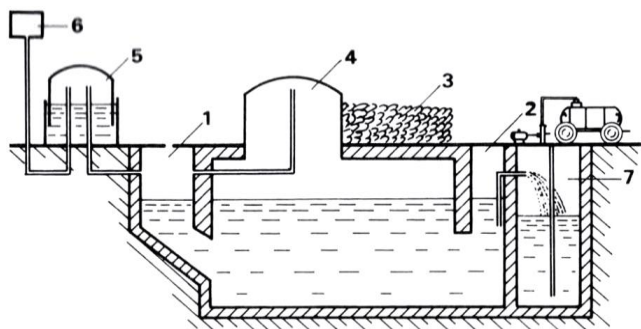

Fig. 1. The scheme of the biogas production system based on Reinhold Darmstadt's method: 1-excrement feed, 2 - discharge of excrement after fermentation, 3 - solid excrement after fermentation, 4 - biogas collection chamber, 5 - biogas tank, 6 - use of biogas, 7 - slurry tank with pump. Source: [14]

Rys. 1. Schemat instalacji do wytwarzania biogazu metodą Reinholda Darmstadta: 1 - doprowadzenie odchodów, 2 - odprowadzenie odchodów po fermentacji, 3 - odchody stałe po fermentacji, 4 - komora do gromadzenia biogazu, 5 - zbiornik biogazu, 6 - wykorzystanie biogazu, 7 - zbiornik gnojowicy z pompą. Źródło: [14]

The best known method of producing biogas from the fermentation of a mixture of manure, slurry, sewage and organic waste fragmented in water is the Schmidt-Eggergluss method [18, 14, 13, 5, 2]. This method is designed for large farms with a daily biogas demand ranging from 100 to 300 m³. The system (Fig. 2) comprises the pump, fermentation chamber, sludge tank, biogas tank and tank with excrement stirrer. This fragmented organic matter is pumped into the preliminary tank. After mixing, the mixture is pumped into the fermentation chamber where it is heated up with the steam boiler, and biogas is produced and stored in the biogas tank. This method allows the daily out-

put of 0.75 m³ of biogas per 1 m³ of the fermentation chamber. The disadvantage of this technology is scum formed on the surface of the organic matter in the fermentation chamber as a result of the fermentation process and this scum absolutely needs to be smashed with a stream of liquid or biogas.

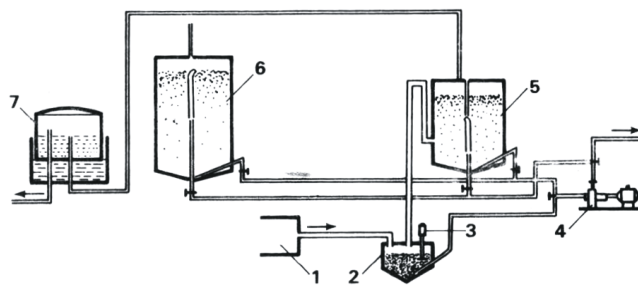

Fig. 2. The scheme of the biogas production system based on the Schmidt-Eggergluss method: 1 - excrement feed, 2 - tank, 3 - stirrer, 4 - pump, 5 - fermentation chamber, 6 - bio-sludge tank, 7 - biogas tank. Source: [14]

Rys. 2. Schemat instalacji do wytwarzania biogazu metodą Schmidta-Eggerglussa: 1 - doprowadzenie odchodów, 2 - zbiornik, 3 - mieszadło, 4 - pompa, 5 - komora fermentacyjna, 6 - zbiornik bioszlamu, 7 - zbiornik biogazu. Źródło: [14]

In order to obtain the highest calorific value of biogas and deactivate a relatively high quantity of waste used in biogas plants, those technologies are constantly improved [23]. It is worth mentioning the agricultural biogas installation developed by the Institute of Technology and Life Sciences in Warsaw and designed for the production of biogas from livestock excrement in the number of 20-60, 40-60, 100-1000 livestock units [4]. The scheme of various biogas installation configurations is shown in Figure 3. Its advantage for rural areas is the option to flexibly choose fermentation chambers. Depending on the number of livestock units, there are used fermentation chambers of volumes from 25 to 500 m³ (and its multiple). The advantage of the biogas installation is the construction of fermentation chambers [21]. The biogas plant's walls are made from small-size arched elements, whereas the composting plant's walls are made from rectangular elements. This eliminates the use of shuttering when erecting the walls placed on poles, and ensures good airtightness of chambers. However, this kind of solutions allows a reduction in concrete usage by about 25% and a workload reduction by about 20-30%. The result of the anaerobic digestion of biomass (slurry utilization) is biogas, bio-fertilizer and electric power [22] or thermal energy. In this installation 1 m³ of the fermentation chamber produces 0.8 m³ of biogas per day. This technology is especially profitable for a large number of livestock (above 200 livestock units). For the plant with a capacity of 200 m³ and the daily processing of 5-7 tonnes of liquid waste, the plant construction cost is estimated at about PLN 300-400 thousand [22, 5].

3. The list of biomass for needs of the production capacity of renewable energy

For agricultural biogas plants supplied with animal production waste, the potential source of raw materials is primarily farms that breed a large number of livestock.

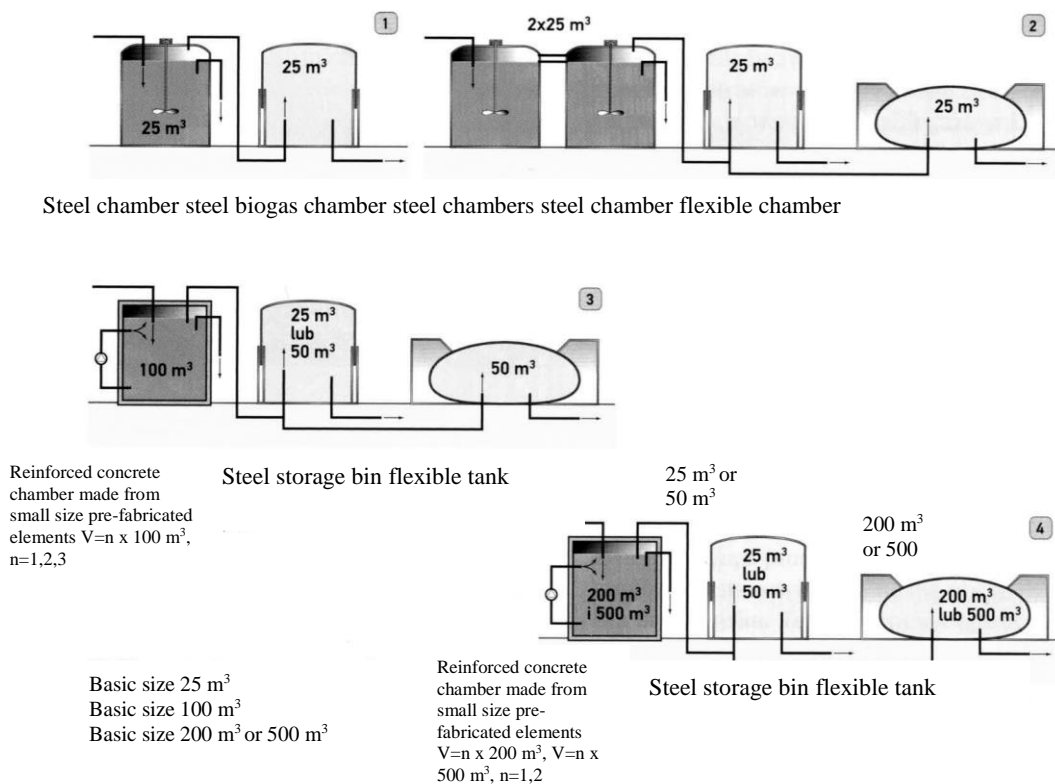

Fig. 3. Schematic diagrams of biogas systems with the fermentation chamber with a volume from 25 m^3 to 500 m^3 (and its multiple). Source: [4]

Rys. 3. Schematy ideowe instalacji biogazowych z komorą fermentacyjną o pojemności od 25 do 500 m^3 (i wielokrotności). Źródło: [4]

Table 1. The biomass output (animal excrement) in the production of farm animals kept in soil and bedding, shallow bedding, and non-bedding systems. Status as of 2012 for 3 communes of the Wielkopolska Province on the basis of the survey results obtained by the Institute of Technology and Life Sciences from 82 farms as part of: Multiannual Programme for the period 2011-2015

Tab. 1. Uzysk biomasy (odchodów zwierzęcych) w produkcji zwierząt hodowlanych w systemie utrzymania głębokościółkowym, płytkościółkowym i beżściółkowym. Stan na 2012 rok dla 3 gmin województwa wielkopolskiego, na podstawie wyników badań ankietowych ITP Oddział Poznań z 82 gospodarstw rolnych, w ramach Programu Wieloletniego na lata 2011-2015

Commune	Animal production	Livestock units*	List of livestock units according to the animal keeping system			Biomass output (animal excrement) Prepared under [3]		
			Deep bedding	Shallow bedding	No bedding	Manure	Liquid manure	Slurry
			Σ	Σ	Σ	tonnes per year ⁻¹	cubic metres per year ⁻¹	cubic metres per year ⁻¹
Budzyń	Cattle	638.7	183.8	454.9	---	7306.0	2274.5	---
	Pigs	483.4	175.6	300.0	7.7	5634.7	1500.2	154.0
	Horses	38.1	20.0	18.1	---	172.4	---	---
	Total	1160.2	379.4	773.0	7.7	13113.1	3774.7	154.0
Każmierz	Cattle	1077.5	236.8	840.8	---	11958.8	---	---
	Pigs	85.9	---	85.9	---	859.0	429.5	---
	Horses	---	---	---	---	---	---	---
	Total	1163.4	236.8	926.7	---	12817.8	429.5	---
Kostrzyn Wlkp.	Cattle	2048.2	1128.3	518.9	401.0	22113.9	2594.7	8020.0
	Pigs	74.0	8.9	65.1	---	784.8	325.7	---
	Horses	99.7	---	3.6	---	14.4	---	---
	Total	2222.0	1137.2	587.7	401.0	22913.1	2920.4	8020.0
Total	Cattle	3764.4	1548.9	1814.6	401.0	41378.7	4869.2	8020.0
	Pigs	643.3	184.5	451.1	7.7	7278.5	2255.4	154.0
	Horses	137.8	20.0	21.7	---	186.8	---	---
Total:		4545.5	1753.4	2287.4	408.7	48844.0	7124.6	8174.0

*LU (livestock unit) - a standard measurement unit that allows the aggregation of livestock on a farm; a reference unit is a dairy cow of 500 kg

Source: Own work / Źródło: opracowanie własne

Biogas plants located in rural areas with a considerable number of livestock need to be equipped with pumps, pipe lines or closed conveyor belts to directly collect and feed slurry, manure and dry waste [16]. In order to carry out this venture, it is necessary to know the production quantity and capacity of organic waste, among others, coming from the animal production.

Any relevant information in this respect come from reports of the Central Statistical Office and local state authorities (Agencies for the Restructuring and Modernisation of Agriculture, Veterinary Inspectorates, Agricultural Advisory Centres), as well as from programme research conducted by scientific centres in agreement with the Ministry of Agriculture and Rural Development [16, 19]. In order to determine the production capacity of renewable energy (agricultural biogas), any collected data are processed and tabularized, and then used to determine the production capacity of renewable energy by means of software [10] or formulae [8, 9]. An example of the biomass data (animal excrement) in the animal production used to determine the production capacity of renewable energy is shown in Table 1.

4. Assumptions and work methodology

In order to determine the capacity of energy from biomass available in the animal production in three communes of the Wielkopolska Province (Budzyń, Kaźmierz, and Kostrzyn Wielkopolski), the total value of livestock units shown in Table 1 was used. It was assumed that in those three communes of Budzyń, Kaźmierz and Kostrzyn Wielkopolski animal excrement (biomass) was the total capacity to be used by biogas plants for energy generation. Based on the results of availability of biomass for energy purposes survey from 82 farms, which was conducted by Institute of Technology and Life Sciences Poznań Branch, because of lack of information about biomass from poultry excrement, poultry was excluded. Due to the fact that in those analysed communes cattle and pigs are the majority of livestock and biogas plants located on farms are profitable only if livestock units are greater than 200 [5, 9], the capacity of energy from biomass was determined with the exclusion of horses. On the basis of computational input data concerning the production of biogas from animal excrement [8], the production capacity of energy from agricultural biogas was determined with the use of average values (Table 2). However, the shallow bedding system designed for cattle and pigs the adopted rates for liquid manure equal to 1.61 and 0.93 m³·(livestock units · d)⁻¹.

The production capacity of energy E_w MWh·rok⁻¹ of agricultural biogas from animal biomass (excrement of cattle and pigs) is determined according to the following formula:

$$E_w = \frac{L_{DJP} \cdot P_b \cdot (365 \cdot year^{-1}) \cdot 21.5 \cdot 0.8}{3600} \quad (1)$$

- L_{DJP} - total number of livestock units [table 1],
- P_b - production of m³ of biogas per day with respect to one livestock unit, m³·(livestock units · d)⁻¹ [Table 2],
- 21.5 - calorific value of biogas, MJ·m⁻³
- 0.8 - efficiency of biomass combustion equipment,
- 365 - number of days in a year,
- 3600 - conversion factor (MJ to MWh).

The test results are shown in tables and analysed.

5. Results

The presented computational data (Table 3) show that the production capacity of agricultural biogas energy (E_w MWh·year⁻¹) from available biomass (excrement of cattle and pigs) in rural areas of the analysed communes of the Wielkopolska Province (Budzyń, Kaźmierz, and Kostrzyn Wielkopolski) is diversified. The deep bedding, shallow bedding and non-bedding system used to keep livestock (Table 1) in 2012 this capacity ranged from 12.5 to 4328.8 MWh·year⁻¹. Its greatest capacity was achieved in the cattle production from 705.2 to 4328.8 MWh·year⁻¹, whereas the smallest in the pig production (from 12.5 to 486.6 MWh·year⁻¹). This results from the non-homogeneous livestock population on farms in the analysed communes.

As for the total number of livestock units, the greatest production capacity of renewable energy from biomass in the cattle production (6506.0 MWh·year⁻¹) was in the commune of Kostrzyn Wielkopolski. Given the nature of the production of this kind of animals, in this commune the basic source of biomass for the production of agricultural biogas is manure whose production capacity is estimated at 4328.8 MWh·year⁻¹. On the other hand, in the communes of Budzyń and Kaźmierz the basic source of biomass with the production capacity of renewable energy of 1277.2 and 2360.5 MWh·year⁻¹ is liquid manure. Considering the total number of cattle (Table 1) in 2012 in the analysed communes, the total production capacity of renewable energy equals to 11757.2 MWh·year⁻¹.

Table 2. Production of agricultural biogas from animal excrement. List on the basis of: [8]

Tab. 2. Produkcja biogazu rolniczego z odchodów zwierzęcych. Zestawiono na podstawie: [8]

Parameter	*Unit	Function	Cattle		Pigs pigsty	
			M	*S	**M	***S
Biogas production	m ³ ·(livestock units · d) ⁻¹	Min.	1.50	0.56	0.60	
		Max.	2.90	1.50	1.25	
		Average	2.20	1.03	0.93	

*m³·(livestock unit · d)⁻¹ - a production unit of m³ of biogas per one large livestock unit per day

**M - manure,

***S - slurry

Table 3. The production capacity of renewable energy E_w MWh·year⁻¹ from biomass (manure, liquid manure, slurry) obtained in 2012 in the production of cattle and pigs in the area of three communes (Budzyń, Kaźmierz, and Kostrzyn Wielkopolski) of the Wielkopolska Province with respect to the total number of livestock units

Tab. 3. Potencjał wytwórczy energii odnawialnej E_w MWh·rok⁻¹ z biomasy (obornika, gnojówki, gnojowicy) uzyskanej w 2012 roku w produkcji bydła i trzody chlewnej na terenie trzech gmin (Budzyń, Kaźmierz, Kostrzyn Wielkopolski) województwa wielkopolskiego, w odniesieniu do sumarycznej liczby DJP

Commune	Animals		Manure	Liquid manure	Slurry	Total:
	Type	Σ livestock units				
Budzyń	Cattle	638.7	705.2	1277.2	---	1982.4
Kaźmierz		1077.5	908.3	2360.5	---	3268.8
Kostrzyn Wlkp.		2048.2	4328.8	1456.9	720.3	6506.0
Total:		3764.4	5942.2	5094.6	720.3	11757.2
Budzyń	Pigs	483.4	284.8	486.6	12.5	783.9
Kaźmierz		85.9	---	139.3	---	139.3
Kostrzyn Wlkp.		74.0	14.4	105.6	---	120.1
Total:		643.3	299.3	731.6	12.5	1043.3
Total:		4407.7	6241.5	5826.2	732.8	12800.5

Source: Own work / Źródło: opracowanie własne

Considering the production of pigs in the communes of Budzyń, Kaźmierz, and Kostrzyn Wielkopolski, the basic source of biomass is liquid manure whose production capacity of renewable energy is 731.6 MWh·year⁻¹. Its greatest energetic values (486.6 MWh·year⁻¹) are reported in the commune of Budzyń, and the smallest (105.6 MWh·year⁻¹) in the commune of Kostrzyn Wielkopolski. Considering the total production capacity of renewable energy in the production of pigs the greatest capacity is reported in the commune of Budzyń (783.9 MWh·year⁻¹). On the other hand, this capacity in the communes of Kaźmierz and Kostrzyn Wielkopolski equals to 139.3 and 120.1 MWh·year⁻¹, respectively. In those communes the total production capacity of renewable energy from biomass was 1043.3 MWh·year⁻¹. However, in 2012 the total production capacity of renewable energy from biomass (manure, liquid manure, slurry) from the animal production (cattle and pigs) equalled to 12800.5 MWh·year⁻¹.

6. Summation

Considering the development of the farm animal production and the growing demand for energy in rural areas, it is necessary to disseminate information on technologies used to produce agricultural biogas from animal biomass (excrement of cattle and pigs). However, the decision to start the production of agricultural biogas requires some knowledge about agro-energy biogas facilities and the availability of biomass for energetic purposes. Therefore, in order to meet expectations, this study describes selected technical and technological solutions for the production of agricultural biogas and indicates the method of collecting and compiling data on the volume of biomass in the animal production and their mathematical conversion into the production capacity of energy of agricultural biogas. This study is the continuation of the activities of the Institute of Technology and Life Science in Poznań under Contract No GZ-MW-0661-1/2013 made with the Minister of Agriculture and Rural Development [Multiannual Programme for the period 2011-2015]. It is addressed to individuals and state units interested in this issue and the development of

renewable energy sources, including agro-energy biogas facilities, in rural areas.

7. Conclusions

1. It is essential to have knowledge of the volume and technologies of anaerobic digestion of biomass and of the ability to estimate it on an energetic basis in order to determine in the production of farm animals and use in practice the production capacity of renewable energy from biomass (animal excrement).
2. In the area of the analysed communes of the Wielkopolska Province (Budzyń, Kaźmierz, and Kostrzyn Wielkopolski) the production capacity of agricultural biogas energy from animal biomass (excrement of cattle and pigs) was 12800.5 MWh·year⁻¹ in 2012. The greatest capacity was reported in the cattle production and ranged from 705.2 to 4328.8 MWh·year⁻¹, whereas the smallest one was in the pig production and ranged from 12.5 to 486.6 MWh·year⁻¹.
3. In the cattle production, the greatest production capacity of renewable energy from the available biomass (6506.0 MWh·year⁻¹) was in the commune of Kostrzyn Wielkopolski. Given the nature of the production of farm animals in this commune, the basic source of biomass for the production of agricultural biogas is manure whose production capacity is estimated at 4328.8 MWh·year⁻¹.
4. Considering the production of pigs in the communes, the basic source of biomass is liquid manure whose production capacity of renewable energy is 731.6 MWh·year⁻¹. Its greatest energetic values (486.6 MWh·year⁻¹) are reported in the commune of Budzyń, and the smallest (105.6 MWh·year⁻¹) in the commune of Kostrzyn Wielkopolski.

8. References

- [1] Bień J., Bień B.: Biogazownia rolnicza elementem programu gospodarki odpadami i wytwarzania zielonej energii w gminie (Agricultural Biogas Plant as an Element of Waste Management Plant and Green Energy Production in Local Municipality). Inżynieria i ochrona środowiska, 2010, 13 (1), 17-27.
- [2] Bruns E., Ohlhorst D., Wenzel B., Köppel J.: Renewable Energies in Germany's Electricity Market: A Biography of the Innovation Process, Springer, 2011.

- [3] Dz. U. 2005, Nr 17, poz. 142. Rozporządzenie Rady Ministrów z dnia 18 stycznia 2005 r. w sprawie szczegółowych warunków i trybu udzielania pomocy finansowej na dostosowanie gospodarstw rolnych do standardów Unii Europejskiej objętej planem rozwoju obszarów wiejskich.
- [4] Głaszczka A., Wardal W.J., Romaniuk W., Domasiewicz T.: Biogazownie rolnicze. Seria: Technologie Energii Odnawialnej. MULTICO Oficyna Wydawnicza, Warszawa, 2010.
- [5] Gronowicz J.: Niekonwencjonalne źródła energii. Wyd. Instytut Technologii Eksploatacji – PIB, Poznań-Radom, 2010.
- [6] Grzybek A.: Potencjalne możliwości produkcji energii odnawialnej przez polskie rolnictwo. W: Odnawialne źródła energii. Ekspertyza dotycząca ekonomicznych uwarunkowań rozwoju poszczególnych rodzajów odnawialnych źródeł energii na obszarach wiejskich oraz ich wpływ na poprawę opłacalności produkcji rolniczej w Polsce w kontekście WPR. Red. J. Seremak Bulge. IERiGŻ, Warszawa, 2012.
- [7] GUS: Gospodarka paliwowo-energetyczna w latach 2009, 2010. Informacje i opracowania statystyczne, Warszawa, 2011.
- [8] Innowacyjność podejmowanych działań w obszarze odnawialnych źródeł energii: Projekt realizowany przez Unię Europejską ze środków Europejskiego Funduszu Społecznego oraz ze środków budżetu Państwa. Umowa nr Z/2.08/II/2.6/12/06/U/20/06. Uniwersytet Zielonogórski, Wydział Inżynierii Łądowej i Środowiska, Zielona Góra, 2008.
- [9] Klugmann-Radziemska E.: Odnawialne źródła energii. Przykłady obliczeniowe. Wyd. Politechniki Gdańskiej, Gdańsk, 2013.
- [10] Konieczny R.: Model komputerowy do monitorowania zasobności terenów wiejskich w biomasę. Na podstawie danych podstawowych (arealu zbóż, plonu ziarna, liczby zwierząt gospodarskich, wielkości DJP, powierzchni lasu, objętości drewna, arealu roślin energetycznych). Opracowanie ITP, Poznań, 2013.
- [11] Kotowski W.: Gospodarka odpadami oraz rekultywacja hałd kopalnianych. Oficyna Wydawnicza Politechniki Opolskiej, Opole, 2000.
- [12] Kowalczyk-Juško A., Mazanek A.: Biogaz rolniczy – charakterystyka, substraty, wykorzystanie (Agricultural biogas - characteristics, substrates and its use). Combustion Engines, 2012, 1(148), 8-14.
- [13] Lewandowski M. W.: Proekologiczne odnawialne źródła energii. Wydawnictwo Naukowo-Techniczne, Warszawa, 2006.
- [14] Miszczak M., Waszkiewicz Cz.: Energia słońca, wiatru i inne. Biblioteka Młodego Technika. Instytut Wydawniczy „Nasza Księgarnia”, Warszawa, 1988.
- [15] Myczko A., Konieczny R.: Istota biogazowni oraz procesy technologiczne i obiekty w biogazowniach. Budownictwo na obszarach wiejskich. Nauka, praktyka, perspektywy. Monografie - Politechnika Lubelska. Wyd. Politechnika Lubelska, 2013, 149-160.
- [16] Myczko A., Myczko R., Kołodziejczyk T., Golimowska R., Lenarczyk J., Janas Z., Kliber A., Karłowski J., Dolska M.: Budowa i eksploatacja biogazowni rolniczych. Poradnik dla inwestorów zainteresowanych budową biogazowni rolniczych. Wyd. ITP, Warszawa-Poznań, 2011.
- [17] Pawlak J.: Produkcja biogazu w rolnictwie – możliwości i ograniczenia (Biogas production in agriculture - potentialities and barriers). W: Problemy intensyfikacji produkcji zwierzęcej z uwzględnieniem infrastruktury, ochrony środowiska i produkcji energii alternatywnej. Opracowanie monograficzne. Instytut Technologiczno-Przyrodniczy w Falentach, Oddział Warszawa. Wyd. ITP, Falenty, 2013.
- [18] Persson S.P.E., Bartlett H.D., Branding A.E., Regan R.W.: Agricultural Anaerobic Digesters. Design and Operation. Bulletin 827. The Pennsylvania State University, College of Agriculture, Agricultural Experiment Station, University Park, Pennsylvania, 1979.
- [19] Program Wieloletni na lata 2011-2015. Standaryzacja i monitoring przedsięwzięć środowiskowych, techniki rolniczej i rozwiązań infrastrukturalnych na rzecz bezpieczeństwa i zrównoważonego rozwoju rolnictwa i obszarów wiejskich” Priorytet 3. Działanie 3.1. Monitoring i kompleksowa ocena zasobu odnawialnych źródeł energii na potrzeby planowania, rozwoju i lokalizacji instalacji agrotechnicznych. Umowa nr GZ-MW-0661-1/2013 zawarta pomiędzy Ministrem Rolnictwa i Rozwoju Wsi, a Instytutem Technologiczno-Przyrodniczym w Falentach.
- [20] Rocson K. N.: Wpływ bentonitu i chlorku żelazawego na zmiany ilościowe i jakościowe w produkcji biogazu z biomasy odpadowej. Praca doktorska pod kierunkiem prof. Czesława Opalińskiego, Wrocław, 1994.
- [21] Romaniuk W., Głaszczka A., Biskupska K.: Analiza rozwiązań instalacji biogazowych dla gospodarstw rodzinnych i farmerskich. Inżynieria w Rolnictwie. Monografie 2083-9545, nr 9. Wyd. Instytutu Technologiczno-Przyrodniczy, Falenty, 2012.
- [22] Romaniuk W., Głaszczka A.: Utylizacja odpadów i pozyskiwanie energii w biogazowniach rolniczych. Ekopartner, 1999, 9, 8-9.
- [23] Szlachta J.: Możliwości pozyskiwania biogazu rolniczego jako odnawialnego źródła energii. Ekspertyza. W: Rozwój potencjału innowacyjnego członków Sieci Naukowej „Agroinżynieria dla rozwoju zrównoważonego rolnictwa, przemysłu rolno-spożywczego i obszarów wiejskich”. Umowa nr UDA-POKL.04.02.00-00-014/08-00 z dnia 16.10.2008. Instytut Inżynierii Rolniczej, Uniwersytet Przyrodniczy, Wrocław, 2009.
- [24] Szwedziak K., Matuszek D.: Rozwój biogazowni rolniczych w województwie opolskim. W: Problemy intensyfikacji produkcji zwierzęcej z uwzględnieniem infrastruktury, ochrony środowiska i produkcji energii alternatywnej. Opracowanie monograficzne. Instytut Technologiczno-Przyrodniczy w Falentach, Oddział Warszawa. Wyd. ITP, Falenty, 2013.
- [25] Niemiecka droga do biogazowego sukcesu [online]. Dostęp 26.08.2014: www.farmer.pl, 2013.

Acknowledgments: *The work is financially supported by the Minister of Agriculture and Rural Development under Contract No GZ-MW-0661-1/2013 made with the Institute of Technology and Life Sciences in Falenty and the Minister of Agriculture and Rural Development [Multiannual Programme for the period 2011-2015].*