

## THE POSSIBILITY OF USING SOLAR AIR COLLECTOR INTEGRATED WITH PHOTOVOLTAIC MODULES FOR AIR EXCHANGE IN ORGANIC FARMS

### Summary

The system comprising an air collector and a photovoltaic panel presented in this study allows an effective twenty-four-hour continuous supply of air exchange. The photovoltaic panel linked with the collector provides electricity to the fan that forces air circulation which, in combination with batteries, permits continuous operation. Solar energy through forced convection heats the air used in the drying process. Because the system uses solar energy (designed for this system), it is not dependent on electricity or other costly forms of energy. In the organic farm can be used for drying agricultural crops and herbs and for heating house and farm buildings.

**Key words:** solar air collector, organic farms

## OCENA MOŻLIWOŚCI WYKORZYSTANIA SŁONECZNEGO KOLEKTORA POWIETRZNEGO ZINTEGROWANEGO Z UKŁADEM FOTOWOLTAICZNYM W GOSPODARSTWACH EKOLOGICZNYCH

### Streszczenie

System zawierający kolektor powietrza oraz panel fotowoltaiczny przedstawione w niniejszym opracowaniu umożliwia przez dwadzieścia cztery godziny ciągłą wymianę powietrza. Panel fotowoltaiczny połączony z kolektorem dostarcza energię elektryczną do wentylatora, który wymusza przepływ powietrza. W połączeniu z baterią, umożliwia to ciągłą jego pracę. Energia słoneczna przez wymuszoną konwekcję ogrzewa powietrze wykorzystywane w procesie suszenia. Ponieważ system wykorzystuje energię słoneczną to nie jest zależny od energii elektrycznej lub innych kosztownych form energii. W gospodarstwie ekologicznym może być używany do suszenia płodów rolnych, roślin leczniczych i przyprawowych oraz do wspomagania ogrzewania i cyrkulacji powietrza w domach mieszkalnych oraz budynkach gospodarczych.

**Słowa kluczowe:** solarny kolektor powietrzny, gospodarstwa ekologiczne

### 1. Introduction

Solar collectors serve the purpose of the conversion of solar radiation into heat energy. At present, it is above all liquid collectors that are used to this aim in Poland. In them, polypropylene glycol collects heat from the absorber. Such collectors are increasingly more commonly used to heat warm tap water and to support heating of buildings. However, no solar collectors are known or used where air collects heat from the absorber. The air used as working medium has many advantages. These include: accessibility, safety in case of leakage outside of the system, no need to provide and control the tightness, and the possibility of direct air heating [10]. Solar air collectors have wide applications among others in the provision of heat to ground heat stores, in air exchange in storage halls or in livestock buildings [4, 7, 8, 11]. They can also be used in those technological processes which require the provision of heat or an exchange of air, that is e.g. in drying the agricultural produce or drying up of wood [1, 2, 3, 6, 9]. The ability to use a wide range of solar air collectors has led the author to create a prototype of such a device, having undergone a preliminary analysis and assessment of interest in this product from organic farms.

### 2. Structure and effectiveness of the solar air collector

The possibilities of the use of solar energy in Polish conditions are connected with an adaptation of those devices that use this type of energy to the quantity and distribution of

solar radiation. The density of solar radiation in the annual perspective in Poland ranges from 900 kWh/m<sup>2</sup> in south areas to 1,150 kWh/m<sup>2</sup> in the seaside strip, Podlasie and Lubelszczyzna regions. The greatest insolation, i.e. the number of hours with sun, occurs in Gdynia: 1,671 hours/year, while the smallest is observed in Katowice city: 1,234 hours/year.

In connection with the values quoted, when constructing the solar air collector, particular care was taken concerning the absorbent and the kind of glass which covered it. Owing to the use of an absorber from a copper metal sheet covered with a high-selective absorbent Blue Tec eta plus layer, the coefficient of absorption was 95%. The absorber was covered with a prismatic solar pane of U1 class with the solar radiation transmittance of 91.4%. The absorber adhered to the aluminium walls of the meander. This increased the heat exchange area. The side walls and the rear wall were insulated with mineral wool. To ensure an even air flow through the collector, a meander system was used. This increased the contact area of air flowing through the collector with the absorber (Figure 1). The dimensions of the collector are 2119 mm x 1072 mm x 90 mm. The diameter of the air intake and outlet is 110 mm.

A duct fan with the maximum output of 150 m<sup>3</sup>·h<sup>-1</sup> powered with a photovoltaic panel was used to force the flow of air through the solar air collector. The fan possessed a regulator to permit work with the outputs of 50, 100 and 150 m<sup>3</sup>·h<sup>-1</sup>. The diagram of the system is presented in Figure 2.

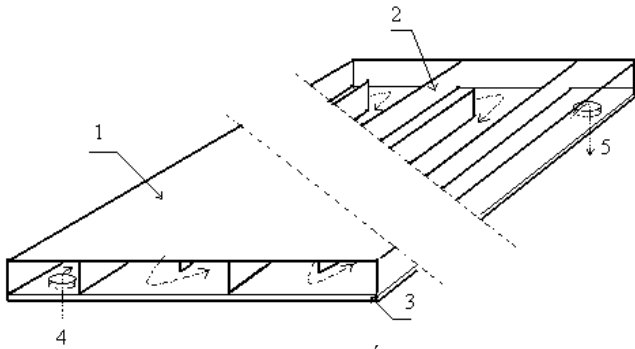

Source: own elaboration / Źródło: opracowanie własne

Fig. 1. Diagram of the solar air collector. 1 – solar glass that covers the absorber, 2 – aluminium meander wall, 3 – mineral wool isolation, 4 – air intake, 5 – air outlet. The patent application no. P.408753

Rys. 1. Schemat solarnego kolektora powietrznego. 1 – szkło solarne, 2 - aluminiowa ścianka meandra oparta na absorberze, 3 – izolacja z wełny mineralnej, 4 – wlot powietrza, 5 – wylot powietrza. Zgłoszenie patentowe nr P.408753

The solar air heater may constitute a separate element, which is gravitationally operated, where air heated by the sun sucks in cool air, it may be an element of a system that consists of a solar air heater, a PV panel ReneSola series Polycrystalline 240W, efficiency 15.70 and battery 24V/120Ah with charging system. This very system was put to tests. The examinations concerning the effectiveness of the operation of the solar air collector were conducted in the months of April and June 2014 in two-hour cycles from 10am to 4pm (three two-hour measurements). The average air temperature in the test was 12.5°C in month IV and 17.5°C in month VI.

The hours of temperature measurements for a specific rate of the air flow were changed in such a manner that within a month, for each rate of the air flow through the collector, the air temperature was measured 3 times in each

of the specified time ranges. The measurement was made with a TR50 resistance thermometer.

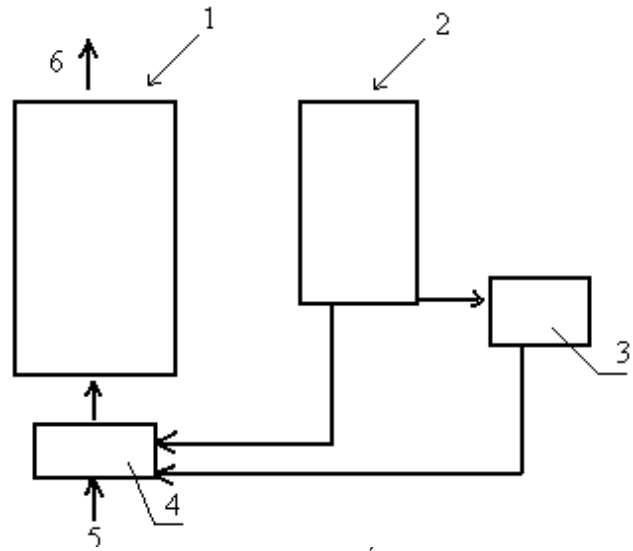

Source: own elaboration / Źródło: opracowanie własne

Fig. 2. Diagram of the solar air collector system with a photovoltaic power system. 1 – solar air collector, 2 - photovoltaic panel, 3 – battery with charging system, 4 – duct fan, 5 – air intake, 6 – air outlet

Rys. 2. Schemat układu solarnego kolektora powietrznego z fotowoltaicznym systemem zasilania: 1 – solarny kolektor powietrzny, 2 – panel fotowoltaiczny, 3 – akumulator z systemem ładowania, 4 – wentylator kanałowy, 5 – wylot powietrza, 6 – wylot powietrza

The results presented in Figure 3 show that the average outlet temperature of the air in April was higher than the outside temperature, and ranged from 16.40°C at air flow rate 150 m<sup>3</sup>·h<sup>-1</sup> to 30.90°C at air flow rate of 50 m<sup>3</sup>·h<sup>-1</sup>. In June these values were respectively from 21.70°C to 39.20°C.

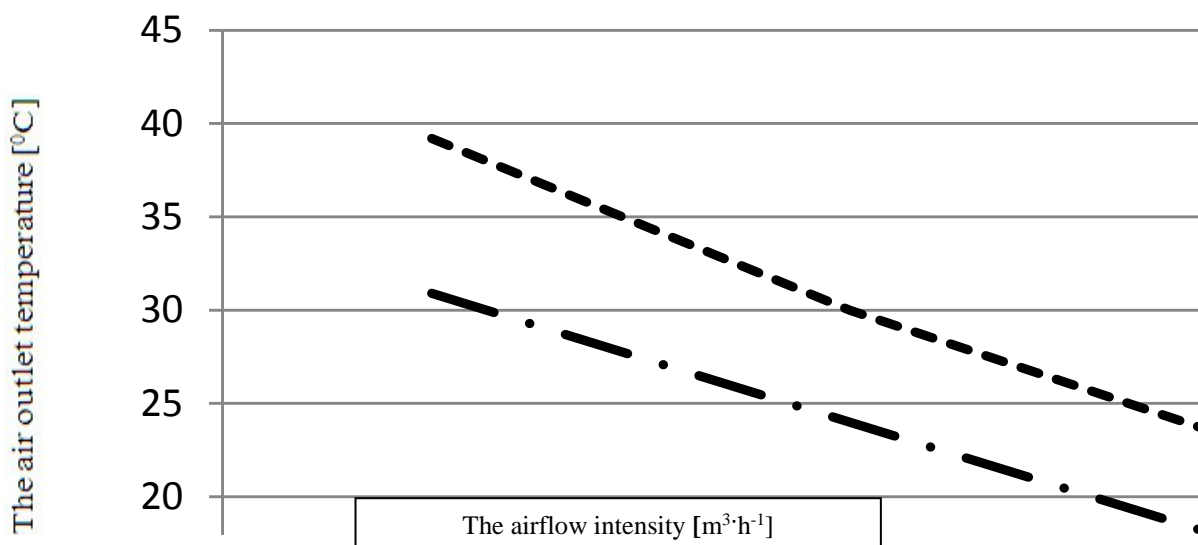

Source: own elaboration / Źródło: opracowanie własne

Fig. 3. Air outlet temperature [°C] depending on the intensity of the air flow and date of the measurement (April, June)

Rys. 3. Temperatura wylotowa powietrza [°C] w zależności od natężenia jego przepływu i terminu pomiaru (kwiecień, czerwiec)

As the results presented in Figure 3 show, a set consisting of an air collector, the PV panel and the fan, at air flow rate of  $50 \text{ m}^3\cdot\text{h}^{-1}$ , is able to increase the air temperature, on average, by  $18.4^\circ\text{C}$  in April and by  $21.7^\circ\text{C}$  in June. At air flow rate of  $150 \text{ m}^3\cdot\text{h}^{-1}$ , the air outlet temperature in April was averagely  $4.6^\circ\text{C}$  higher than the outside temperature, and  $5.0^\circ\text{C}$  higher in June. In April average power air collector was  $897,6 \text{ W}$  in June  $978 \text{ W}$ .

To determine whether the analyzed system can be used on organic farms, where the priority is to care for the biological quality of agricultural crops in the absence of a negative impact on the environment, in the months of IV-VII 2014 there were carried out studies in 121 organic farms producing for a trademark, located in the West Pomeranian and Pomeranian Voivodeships. All the farms produce plants and animals. In seven farms there was also a cultivation of medicinal plants and spices. The data in Table 1 shows that the largest number of organic farmers were interested in the possibility of supporting, by air collector, the drying process of agricultural products. Nearly 40% of farmers indicated the possibility of using such a system in their farms to support, in winter, the heat pump in houses (42.9%) and to heat up and force air circulation in storage buildings (36.4%). The smallest number of farmers were interested in the use of an air collector for drying medicinal plants and spices (nearly 7% in the surveyed households), but by analyzing the structure of production of these farms, it turned out that the interest of such a system was only shown by farmers engaged in cultivation of medicinal plants and spices (6 from 7 farmers involved in the production). Laszuk and Natkaniec [4] think that the solar panels enable to increase the using of solar energy and can contribute to the elimination of the conventional sources of energy for heating buildings. Majewski [5] points out to the possibility of using solar air collectors for drying herbs and agricultural products, indicating their high efficiency.

Table 1. Preferred methods of using solar air collector on an organic farm

Tab. 1. Preferowane sposoby zastosowania solarne kolektora powietrznego w gospodarstwie ekologicznym

Preferred use of the air collector system	% of responses
Drying of agricultural products	56,2
Drying of medicinal plants and spices	6,6
Heating up and air circulation in livestock buildings	17,4
Heating up and air circulation in storage buildings	36,4
Supporting the heat pump in houses	42,9

Source: own elaboration / Źródło: opracowanie własne

An important factor influencing decision to purchase the air collector system is its price and energy efficiency. 68% of surveyed organic farmers expressed interest in buying such a system if its price does not exceed  $9.000 \text{ PLN}$ . Near-

ly one fourth of asked farmers (24%) would be willing to spend on such a system up to  $12.000 \text{ PLN}$ , and 8% of farmers –  $15.000 \text{ PLN}$ .

### 3. Summary

Solar air collectors can be a part of the air ventilation system in farm and storage buildings and in combination with the photovoltaic and battery system, they can force air circulation for 24 hours a day. Research has shown that solar air collectors, even in the northern Polish can effectively heat the air, but their effectiveness is dependent on the intensity of solar radiation. The air temperature at the outlet of the collector can be controlled by air flow rate. The higher rate, the lower air outlet temperature, but more mass of air is heated. Organic farmers are interested in air collector. They would use such a system for drying agricultural products, herbs and spices, supporting heat pumps, heating the air, and forcing its circulation in the storage buildings. However, such a system must be relatively inexpensive and do not exceed  $9.000 \text{ PLN}$  for one segment.

### 4. References

- [1] Bal L.M., Satya S., Naik S.N.: Solar dryer with thermal energy storage systems for drying agricultural food products: A review. *Renewable and Sustainable Energy Reviews*. 2010, 14: 2298-2314.
- [2] Kurowski K. Kolektor słoneczny z absorberem perforowanym. *Czysta Energia*, 2007, 4(66): 18-19.
- [3] Kurowski K.: Wykorzystanie kolektora słonecznego powietrznego z absorberem perforowanym do suszenia wybranych produktów rolniczych, Praca doktorska, IBMER, Warszawa, 2006.
- [4] Laszuk A., Natkaniec P.: Ecologically clean energy from the solar air collectors, *Environment Protection Eng.*, 2006, 1: 57-64.
- [5] Majewski J.: Doświadczalne badania przydatności powietrznych kolektorów słonecznych do wspomagania procesów suszarniczych. *Acta Energetica*, 2011, 3, 39-45.
- [6] Meza-Jimenez J., Ramirez-Ruiz J. J., Diaz-Nunez J. J.: The design and proposal of a thermodynamic drying system for the dehydration of Rosell (*Hibiscus Sabdariffa*) and other agro-industrial products. *African Journal of Agricultural Research*, 2008, vol. 3 (7), 477-485.
- [7] Naphon P., Kongtragool B.: Theoretical study on heat transfer characteristics and performance of the flat-plate solar air heaters, *Int. Comm. Heat Mass Transfer*, 2003, 8: 1125-1136.
- [8] Ong K.S.: Thermal performance of solar air heaters: mathematical model and solution procedure, *Solar Energy*, 1995, 2: 93-109.
- [9] Śmierczalski R, Trębawicz R.: Badanie właściwości eksploatacyjnych próżniowego kolektora słonecznego do grzania powietrza, 2011, PAK, 57, 12: 1567-1569.
- [10] Tchinda R., A review of the mathematical models for predicting solar air heaters systems. 2009, *Ren. Sust. Energy Rev.*, 13: 1734-1759
- [11] Tonui J.K., Tripanagnostopoulos Y.: Improved PV/T solar collectors with heat extraction by forced or natural air circulation. *Renewable Energy*, 2007, 32: 623-637.