

FODDER BRIQUETTES WITH STRAW CONTENT

Summary

The article presents the relationships between unit power consumption of the briquetting process N_i [kWh/ton of product] and briquette density as a function of the following parameters: moisture content of fodder mixture U , clearance coefficient of matrix P , length of matrix openings L , angle of entrance into opening β , gap between matrix and densification roll S_s , diameter of densification roll R_{RI} , percentage straw content S , average length of straw particles L_t . The influence of gap between the matrix and densification roll S_s , and diameter of densification roll R_{RI} on briquette density was discovered to be immaterial.

Key words: briquetting, briquette quality, straw, fodder

BRYKIETY PASZOWE Z UDZIAŁEM SŁOMY

Streszczenie

W artykule przedstawiono zależności energochłonności jednostkowej procesu brykietowania N_i [kWh/tonę produktu] oraz gęstości brykietów w funkcji wilgotności mieszanki paszowej U , współczynnika prześwietu matrycy P , długości otworów w matrycy L , kąta wejścia do otworu β , szczeliny pomiędzy matrycą a rolką zagęszczającą S_s , średnicy rolki zagęszczającej R_{RI} , procentowej zawartości słomy S , średniej długości cząstek słomy L_t . Wpływ szczeliny pomiędzy matrycą a rolką zagęszczającą S_s , średnicy rolki zagęszczającej R_{RI} , na gęstość brykietów okazał się nieistotny.

Słowa kluczowe: brykietowanie, jakość brykietu, słoma, pasza

1. Introduction

According to Dunaj [5], straw is ripe or dried plant stalks. This term has been commonly adopted to describe corn plants, legumes, flax, and rape. As these plants' seed production waste, it is widely used in agricultural and horticultural production, construction, as well as the power industry [7, 8].

As reported by Denisiuk [4], raw fibre is the basic ingredient of straw. It is characterized by a high dry mass content (approx. 85%) and high sorption capacities. The oldest method of straw utilization was, and still is, using it as litter material. Since 1977, a decrease in straw use as litter has been recorded, caused by, among other factors, a reduction in livestock, including a reduction by 30% in the case of cattle [7, 8, 17]. According to Krzywy [18] and Kusińska [19], one of the methods of straw utilization is its use as soil fertilizer in the form of manure or chopped straw, which leads to the creation of humus, which is its biological transformation form.

Another method of straw utilization is its use in fodder production [17].

According to Flachowski [6], straw is a valuable ingredient of volume fodder (e.g. corn), consisting of approx. 75% of high-value food ingredients (cellulose and hemicellulose) and approx. 25% of worthless ingredients (lignin and other incrusting substances and ash, as well as nearly indigestible protein).

The dietary value of straw increases when it is subjected to leaching or ammonia treatment (depending on the used technology) both before and during the briquetting process, in the course of which shredding of particles causes relaxation of the lignin-cellulose complex, and thus easier access to food ingredients for microorganisms in the rumen [6, 11, 13].

According to Flachowski [6, 11, 13], moisture content

of straw should be within the range of 10-18% that makes it possible to carry out the briquetting process.

Example fodder formulations in [%], e.g. for bovine animals for fattening, are shown in table 1.

Tab. 1. Example fodder formulations in [%], e.g. for bovine animals for fattening [11, 13]

Tab. 1. Przykładowe receptury pasz w [%] np. dla bydła [11, 13]

Mixture ingredient	Ingredient content [%]			
	Fodder I	Fodder II	Fodder III	Fodder IV
Straw	30	40	40	50
Dried green fodder	-	10	-	-
Dried beet chips	10	10	10	10
Beet pulp	-	-	20	-
Corn grain (50% of wheat, 50% of barley)	51.5	41.5	36	35.5
Post-extraction meal	5	5	-	-
Urea	1	1	1.5	2
Mineral mixture	2.5	2.5	2.5	2.5

Energy consumption of the process and the quality of the final product depend on the technical and technological parameters of the processes of pelleting or briquetting. Among the most important parameters there are: moisture content of the material, process temperature, type of material, working area, length, diameter, matrix opening geometry [9, 12, 20, 21, 23].

According to Zawisłak [23], among the raw materials most susceptible to pelleting there are: low fibre post-extraction corn, as well as most post-extraction meals. Raw materials with high fibre contents, on the other hand, are less susceptible to pressure agglomeration.

The process of straw briquetting, the parameters influencing the course of this process and the quality of obtained briquettes are also presented in papers [1, 2, 22].

2. Production of fodder briquettes

Production of briquetted fodder is carried out according to the diagram presented in fig. 1.

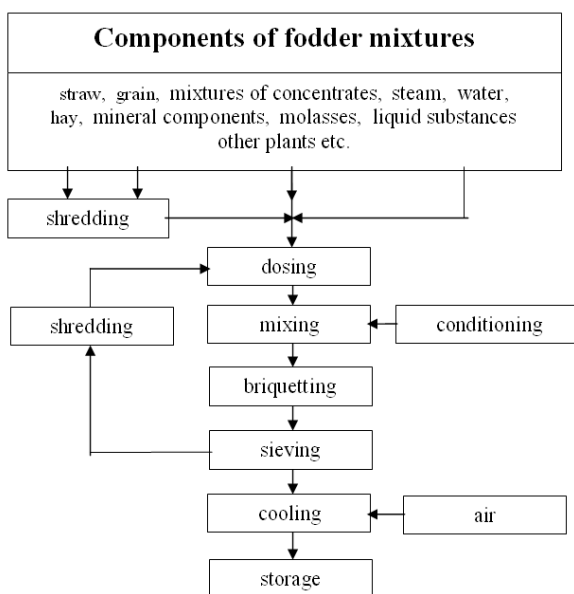

Fig. 1. Diagram of production of agglomerated fodder [14, 15]
Rys. 1. Schemat wytwarzania pasz aglomerowanych [14, 15]

Shredding

The average size of briquetted straw particles has a significant impact on the course of processes and product quality. The degree of shredding should be determined in laboratory tests. With a certain approximation, it can be initially assumed that the average particle size is approx. 0.5 of matrix opening diameter. The granulometric composition of a shredded material has an impact on the involvement of internal bindings between particles, resulting in the product's solid form. Shredding of straw causes relaxation of its lignin-cellulose complex, which facilitates the course of the process to a considerable degree. A content of, for example, shredded corn grain (starch, i.e. binder, content) leads to a significant increase in the number of bindings of the cohesion force type.

Drying

Drying is an optional operation, between the operations of shredding and mixing. It is required when the moisture content of the briquetted raw material exceeds 18-20%. Energy for the heating chamber may be obtained from biomass combustion in the heating chamber boiler, or by using solar energy (from solar collectors).

Mixing

Straw is considered as material "difficult" to briquette, which causes the energy consumption of the process to reach a value as high as 100kWh/ton. For this reason, before a straw component is introduced into the mixer, its lignin-cellulose complex should be relaxed. This can be achieved with the use of additional process operations, e.g. through chemical methods: leaching with sodium compounds, liming, ammonia treatment, biological methods (e.g. adding enzymes or microorganisms to straw), physical methods (e.g. through the action of steam – straw steaming), the action of gamma radiation, and also through processing.

A compromising solution is to mix a material with elevated moisture content with a dry material, which leads to a reduction of the average moisture content. The elevated moisture content of one of the materials will also activate the mechanism of non-pressure pelleting – combining dusty particles of dry material through liquid bridges into agglomerates that are several times larger.

Pressure agglomeration – pelleting, briquetting

The high dynamic loads of pelleting and briquetting working systems result in their relatively high energy consumption and fast wear, at high production costs. Research studies performed by the authors et al. make it possible to promote low-throughput universal devices pelleting and briquetting plant materials that may produce ecological solid fuel (including waste-based), as well as industrial fodder, in medium and large farms and small and medium plant waste processing plants. This is why special attention must be paid to working systems with a flat immovable matrix (a simple design, the existence of various products for which the matrices can be used on both sides, ease of matrix densification rolls replacement, a significantly lower price in comparison with other designs, etc.).

Sieving

As a result of sieving, briquettes of a required quality are obtained. The sieve residue is retrieved for further processing.

Cooling

During (air) cooling, briquettes acquire an increased mechanical durability.

3. The aim of the paper

The aim of the paper was to determine the relationship between unit energy consumption of the briquetting process of fodder mixtures with straw content and density of the obtained briquettes as a function of the main material, process, and construction parameters of the working system.

4. Research methodology

The authors' research into the briquetting process of a fodder mixture containing straw was carried out with the use of an exemplary fodder mixture according to the formulation presented in table 2, with an average moisture content of 12.7%.

Tab. 2. Formulations of the tested fodder mixtures in [%] e.g. for bovine animals for fattening [11, 13]

Tab. 2. Receptury badanych mieszanek paszowych w [%] np. dla bydła opasowego [11, 13]

No.	Mixture components	Ingredient content [%]	
		Mixture B	Mixture B
1.	Straw + NaOH	25	50
2.	Shredded rye grain	20	20
3.	Dried grass	38	13
4.	Shredded beet pulp	5	5
5.	Polfamix	2	2
6.	Molasses	8	8
7.	Urea	2	2
8.	Whey	Added in amounts depending on achieving the required moisture content up to 9% and 16%	

Granulometric distribution of shredded straw (with the use of 10 mm mesh sieves) is shown in fig. 2.

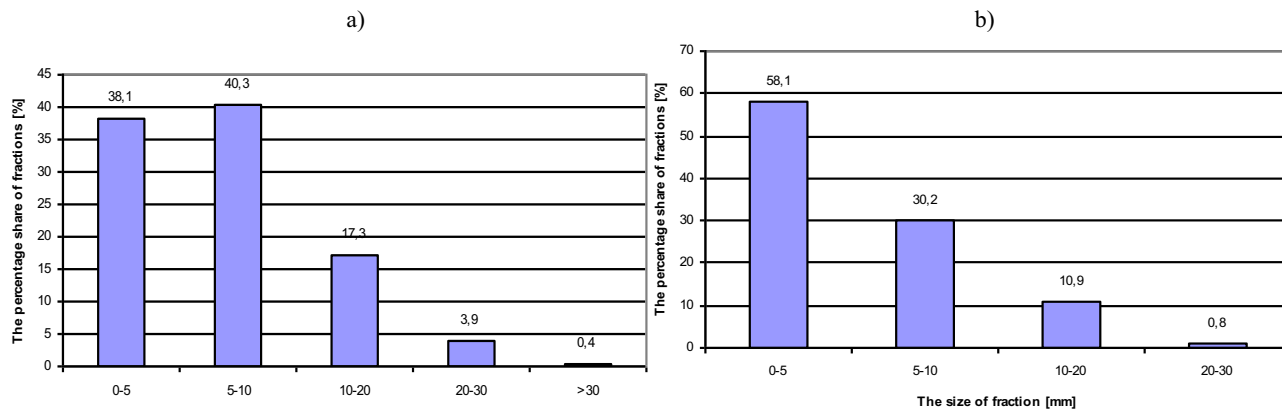

Source: own work / Źródło: opracowanie własne

Fig. 2. Granulometric distribution of shredded straw with the use of a shredder sieve: a) 10 mm, b) 6 mm

Rys. 2. Rozkład granulometryczny rozdrobnionej słomy przy użyciu sita rozdrabniacza: a) 10 mm, b) 6 mm

The average percentage contents of individual fractions of shredded straw are: 0-5 mm – 38.1%, 5-10 mm – 40.3%, 10-20 mm – 17.3%, 20-30 mm – 3.9%, above 30mm – 0.4% and (with the use of a 6 mm mesh sieve); 0-5 mm – 58.1%, 5-10 mm – 30.2%, 10-20 mm – 10.9%, 20-30 mm – 0.8%.

Mixtures with straw contents of $S_1=25\%$ and $S_2=50\%$, at straw shredding values of $L_{t1}=6$ mm and $L_{t2}=10$ mm, and its moisture contents of $U_1=9\%$ and $U_2=16\%$ were tested.

Construction parameters of a flat briquetting matrix are shown in fig. 3.

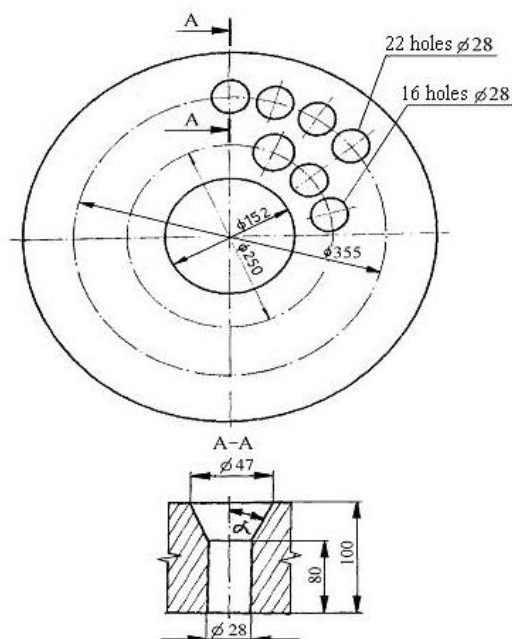

Fig. 3. Scheme of a briquetting matrix [14]

Rys. 3. Schemat matrycy brykietującej [14]

5. Research results

The relationships of unit energy consumption of the briquetting process N_i [kWh-ton⁻¹ of product] in a throughput range of 100 ÷ 300 kg·h⁻¹ as a function of the tested basic material, process, and construction parameters of the working system are shown in the following equation [11, 13]:

$$N_i = (139 - 2U - 1.4P + 0.9L - 0.09S - 0.068L_t + 0.33\beta + 7.45S_s - 0.28R_{R1}) 10^{-3}, \quad (1)$$

where:

U – straw moisture content [%],

P – clearance coefficient of matrix,

L – length of matrix opening [mm],

β – angle of entrance into opening [°],

S_s – gap between matrix and densification roll [mm],

R_{R1} – diameter of densification roll [mm],

S – proportional straw content [%],

L_t – average length of straw particles [mm].

On the basis of the performed tests, determined were the relationships of density of the obtained briquettes ρ as a function of the tested main material, process, and construction parameters of the working system, as shown below [11, 13]:

$$\rho = 1079.6 - 16.54U - 3.42P + 4.48L - 1.16S - 0.73L_t + 1.44\beta \quad (2)$$

6. Summary

1. Straw is a valuable ingredient of volume fodder.
2. The relationships of unit energy consumption of the briquetting process N_i and briquette density as a function of moisture content U , clearance coefficient of matrix P , length of matrix opening L , angle of entrance into opening β , gap between matrix and densification roll S_s , diameter of densification roll R_{R1} , percentage straw content S , and average length of straw particles L_t in a throughput range of 100 ÷ 300 kg·h⁻¹ allow to determine, at the assumed density, the optimum parameters of the briquetting process.
3. The influence of gap between the matrix and the densification roll S_s , and diameter of densification roll R_{R1} , on briquette density was discovered to be immaterial.

7. References

- [1] Adamczyk F., Frąckowiak P., Mielec K., Kośmicki Z.: Problematyka badawcza w procesie zagęszczania słomy przeznaczonej na opał. Journal of Research and Applications in Agricultural Engineering, 2005, 50 (4), 5-8.
- [2] Adamczyk F., Frąckowiak P., Mielec K., Kośmicki Z.: Trwałość brykietów ze słomy przeznaczonej na opał, uzyskiwanych metodą zwijania. Journal of Research and Applications in Agricultural Engineering, 2006, 61 (1), 33-36.
- [3] Adamczyk F.: Wpływ prędkości walców brykietujących na zagęszczenie tworzonego brykietu. Journal of Research and Applications in Agricultural Engineering, 2010, 55 (3), 7-10.

- [4] Denisiuk W.: Słoma – potencjał masy i energii. Inżynieria Rolnicza, 2008, 2 (100), 23-30.
- [5] Dunaj B.: Słownik współczesnego języka polskiego. Warszawa, 2001.
- [6] Flachowsky G.: Granulowane mieszanki paszowe z udziałem słomy. Warszawa: PWRiL, 1983.
- [7] Gradziuk P.: Możliwości energetycznego wykorzystania słomy. Postępy Nauk Rolniczych, 1995, 5, 31-39.
- [8] Gradziuk P.: Możliwości wykorzystania surowców pochodzenia rolniczego na cele energetyczne. Roczniki Naukowe, 1999, Seria. T. 1, z. 3, 233-238.
- [9] Grochowicz J.: Zaawansowane techniki wytwarzania przemysłowych mieszanek paszowych. Lublin: Pagros, 1998.
- [10] Hejft R.: Wpływ prędkości prasowania mieszanki paszowej na wytrzymałość brykietów. Maszyny Ciągniki Rolnicze, 1987, 33 (9), 10-11.
- [11] Hejft R.: Ciśnieniowa aglomeracja pasz i podstawy konstrukcji urządzeń granulująco-brykietujących. Rozprawy Naukowe Politechniki Białostockiej, 1991, 11.
- [12] Hejft R., Obrusiewicz T.: „Badania procesu brykietowania. Techniczno-technologiczne parametry wytwarzania brykietów paszowych z udziałem słomy. Post. Tech. Przetw. Spoż., 1997, 2, 1/2, 23-26.
- [13] Hejft R.: Ciśnieniowa aglomeracja materiałów roślinnych. Biblioteka Problemów Eksploatacji, Radom: ITE, 2002.
- [14] Hejft R., Obidziński S.: Konstrukcja matryc w granulatorze z układem roboczym matryca płaska – rolki zagęszczające. Chemik, 2012, 66 (5), 479-484.
- [15] Hejft R., Obidziński S.: Ciśnieniowa aglomeracja materiałów roślinnych – innowacje technologiczno-techniczne. Część 1. Journal of Research and Applications in Agricultural Engineering, 2012, 57 (1), 63-65.
- [16] Hejft R., Obidziński S.: Aglomeracja odpadowych materiałów pochodzenia roślinnego o podwyższonej wilgotności. MOTROL, 2012, 14, 5, 177-182.
- [17] Kozakiewicz J., Nieściór E.: Słoma i sposoby jej użytkowania w gospodarstwach rolniczych. IUNG Puławy, 1984.
- [18] Krzywy E.: Nawożenie gleb i roślin. Akademia Rolnicza w Szczecinie, 2000.
- [19] Kucińska K.: Słoma jako nawóz. Biuletyn informacyjny DOUPOIT, 1999.
- [20] Laskowski J., Monredon de F.J., Skonecki S., Melcion J.P.: Testing procedure of pelletability of ingredients and compound feeds. International Agrophysics 1994, 8/4, 643-648.
- [21] Laskowski J.: Studia nad procesem granulowania mieszanek paszowych. Rozprawa habilitacyjna. Akademia Rolnicza, Lublin, 1989.
- [22] Niedziółka I., Szymanek M., Zuchniarz A.: Ocena trwałości brykietów wytworzonych z masy roślinnej kukurydzy pastewnej. Inżynieria Rolnicza, 2008, 9 (107), 235-240.
- [23] Zawislak K.: Czynniki wpływające na jakość granulatu. Pasje Przemysłowe, 1996, 2-3, 15-16.

Research performed as part of statutory work S/WBIŚ/2/2015.